

SENTINEL

Surround Audio Program Monitor



- Identifies level and loudness problems
 - Measures level on up to 8 channels
 - Simultaneously measures stereo and mono downmix levels of a surround program
 - Measures loudness to ITU-R BS.1770 (LeqLRB)
- Identifies program compatibility problems
 - Directly measures stereo & mono compatibility
 - Measures LFE bandwidth & phase compatibility
- Identifies signal chain problems
 - Excessive levels and/or Clipping
 - Dead channel detection
 - Hum detection
 - Extracts digital audio metadata and compares:
 - to interface signal
 - to signal characteristics
 - across surround channels
- Easily understood display
 - Generates concise bargraph and text displays
 - All measurements displayed as good=green, marginal=yellow, bad=red
 - Network accessible with standard browsers
 - Generates user-defined alarms (local, remote and e-mail)
- Integrates easily into larger systems
 - Retains previous 24 hours of data for review or download to long term storage
 - Clock / calendar for time & date reference
 - LTC input for correlating results with program
 - Internal sensor reports rack temperature
 - 6 DC inputs for monitoring external parameters (line voltage, security, transmitter power, etc.)
 - Log file translator produces ASCII data for user developed post processing

The shift to surround-sound from stereo brings additional complexity in the audio monitoring and quality assurance functions. The growth associated with these changes has also forced many people unfamiliar with the subtleties of audio into roles where they are responsible for ensuring its quality.

Simplistic multichannel audio level metering products are available from a wide range of manufacturers. Though important, managing signal levels is widely recognized to be only a small part of the task.

Numerous other problems can occur with an audio feed, discovery and correction of which traditionally necessitated continuous aural checks by skilled staff. Intermittent or dead channels, incorrect signal routing, channel reversal, hum, and many other conditions can result in severe dissatisfaction for listener, advertiser, sponsor and management.

The broadcast transition to digital audio has added additional potential for trouble involving incompatibilities in sample rates, word length, emphasis, metadata and more. Along with the shift to low bit-rate coding -with its sensitivity to signal clipping - and the increased dependence on metadata; the potential for audio errors reaching the listener is significantly increased.

The Qualis Audio SENTINEL was designed to address the compound needs of increased monitoring requirements, decreased personnel availability and shrinking budgets. It uses advanced signal processing algorithms to directly answer broadcast user's fundamental questions, rather than merely displaying information requiring further analysis by experienced personnel. Coupled with a truly intuitive human interface and a hardware interface designed to fit into existing infrastructure, the SENTINEL allows significant reductions in operating costs while improving the quality of delivered audio.

The savings in personnel costs and lower error rates can be dramatic. The resulting return on investment can generally be measured in months or even weeks.

MONITORING BASICS - Traditional approaches to maintaining and verifying audio quality depend on a combination of metering and listening. Listening, by definition, requires human involvement. Meters, in their simplest form require someone to watch them. However, people are expensive and trained personnel even more so. Consequently, meters have evolved to include basic limit testing ability, resulting in features such as idle channel detectors and level detectors which can sound alarms. With the recent attention to loudness these same concepts have been applied there.

Aside from simple cases of dead channels or excessive levels causing loudness problems, the assessment of audio quality still requires someone who can interpret the meter results. A moderate degree of audio knowledge is still essential to recognize and address problems before they impact the end user experience. What's more, the likelihood of federal regulation has put new emphasis on the need to document what is broadcast and maintain a "paper trail" to defend against user complaints and potential fines.

The Qualis Audio SENTINEL takes a much more comprehensive approach to audio quality monitoring. It measures a wide range of audio parameters including ones unique to surround sound and digital audio. All measurements are processed by intelligent algorithms and the results are converted to simple green/yellow/red "stoplight" displays. Error conditions (red lights) may trigger an alarm. The user is freed from continuously watching and interpreting a screen, allowing more attention to other aspects of producing, evaluating or transmitting the program.

CONNECTION and OPERATION - The figure illustrates the installation of the SENTINEL into a user's facility. Extensive alarm, notification and logging ability are key SENTINEL features. These make unattended monitoring practical, with complete confidence that problems will produce alarms, the alarms will be noticed and the details required for subsequent remedial action will be logged.

However, should an alarm sound or if there is a desire to

monitor the audio program by a user it can easily be done. Measurements made with the SENTINEL are available for display anywhere on any web browser with access to the network - no special cabling or computer required. Several SENTINELs can be connected throughout the users facilities and the results viewed and compared from any location at any time. Gone is the need to travel to any specific point in the signal chain just to check operation. Attention and, more importantly, travel is only required if and when problems occur.

REAL TIME DISPLAY - The SENTINEL can display its measurement results on any Javascript enabled browser which can access it via an intranet or internet connection. The main page of the SENTINEL is shown at right. Standard digital and analog meter scales are user selected in the SETUP page. The bars at the left show channel levels using the selected metering standard with the maximum values represented by the horizontal line. The channels are downmixed to stereo and mono and their levels displayed on bars to the right. Above each is a numeric display of true peak amplitude, allowing precise metering of signals at or near clipping.

The central section provides loudness, balance, surround compatibility and an octave resolution audio spectrum display. Additional displays may be accessed using the selection buttons at the left.

COMPATIBILITY - Stereo audio requires minimal out-of-phase content between channels to insure proper compatibility with monaural reproduction. Monitoring products for stereo audio often do this by using a Lissajous (X/Y scope) display of left vs. right with a correlation indicator that shows the ratio of in-phase to anti-phase content. Surround sound audio increases the complexity with the multiplied possibility for phase cancellations - all to be watched at once! The important question: "is any part of my program going to significantly change in level when reproduced in stereo or mono?" goes unanswered. Complex visual displays and additional correlation indicators - to handle up to 10 possible phase conflicts - make monitoring difficult even

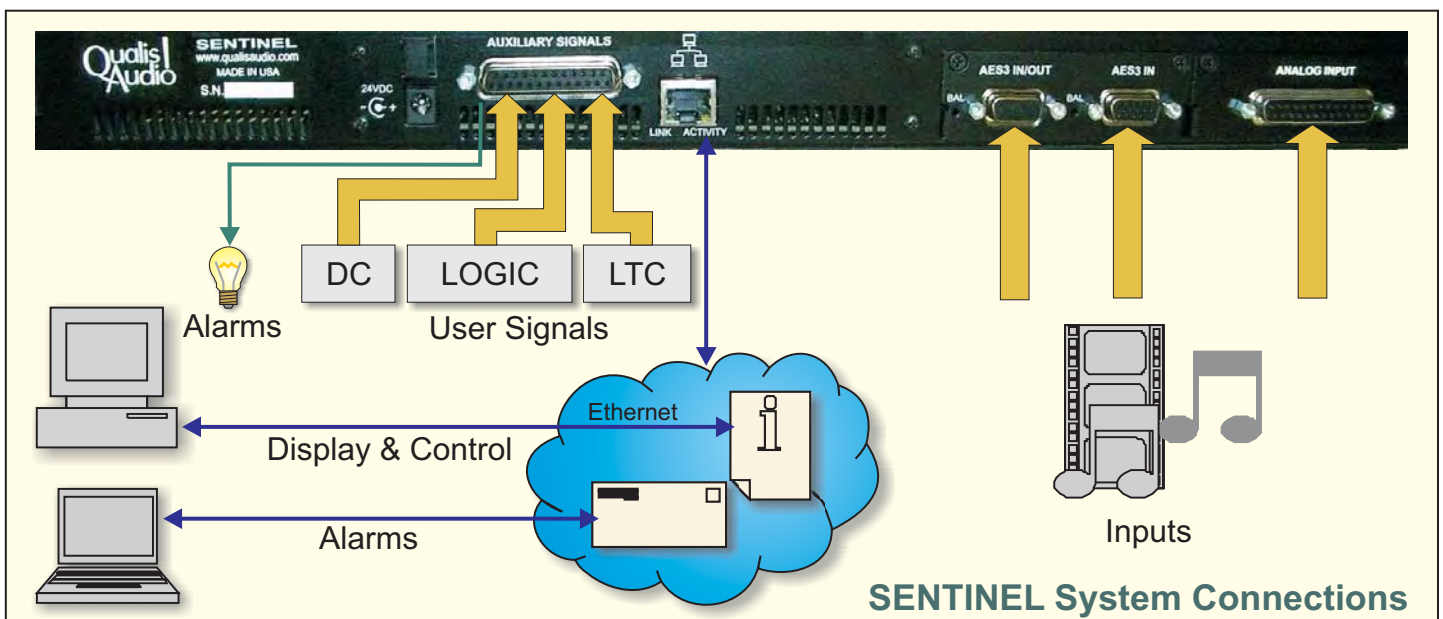

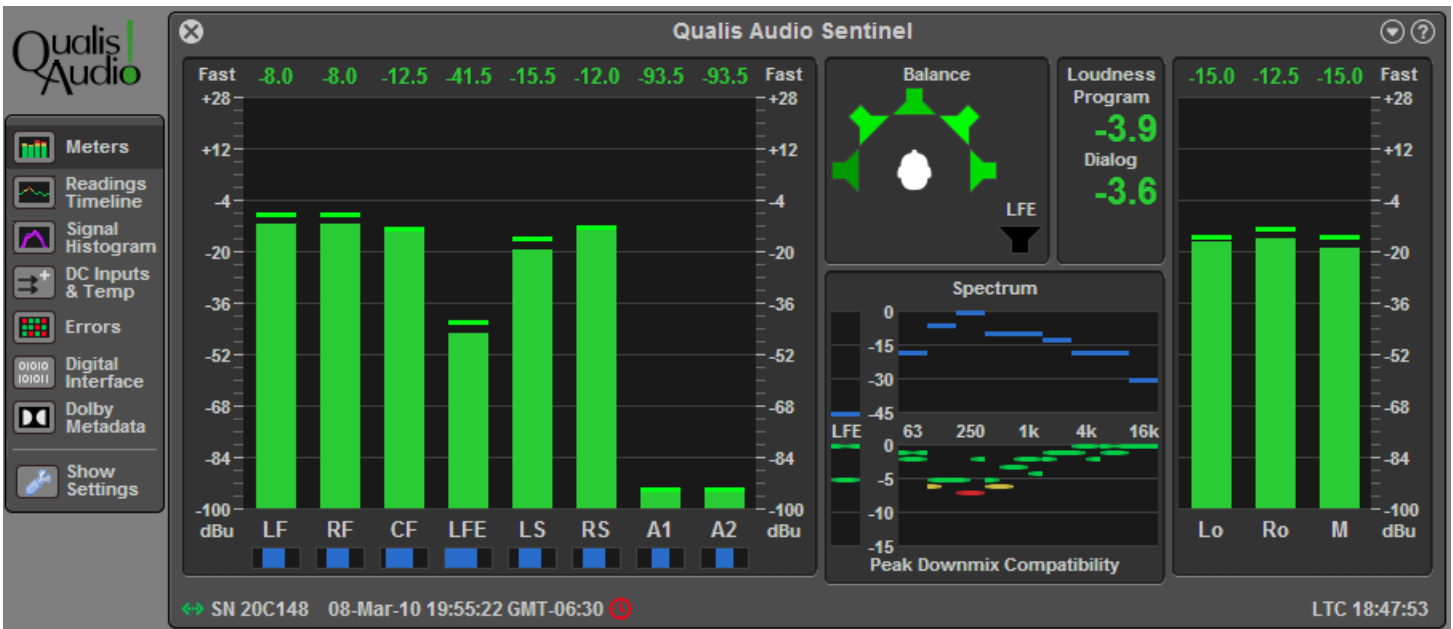

for personnel experienced with surround audio.

The Qualis Audio SENTINEL takes a different approach. It *directly* assesses stereo and mono compatibility of a surround mix. The measurements are converted to a set of numerical results indicating the amount of signal lost by downmixing as a function of frequency. These values may be tested and error conditions may trigger an alarm. The user is freed from watching and interpreting a screen, allowing attention to be given elsewhere where it may be needed more.

All input channels and the downmixes are analyzed in the frequency domain. The power of each component in the original signals is compared to its power in the downmixed signals. The results are grouped by octave band and summarized in the Downmix Compatibility display. If the power is lower in one or more downmixed signals there has been cancellation. Moderate reductions result in yellow indicators while severe reductions are shown in red. The frequency at which errors occur helps identify the material affected. Errors between 250Hz and 4kHz suggest dialog problems, below 250Hz generally impact special effects and those above 4kHz affect ambience.

BALANCE - Graphical multichannel displays based on the Lissajous display concept are also used to infer level balance around the sound field. The SENTINEL BALANCE display supplies this same information in a more intuitive way. The fraction of program power

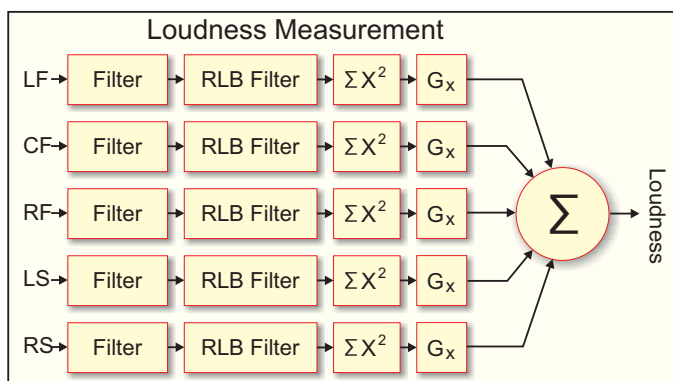

contributed by each surround channel is computed and sets the brightness of the corresponding loudspeaker icon. For example a program with "phantom mono" shows equally bright left and right front speaker icons.

LOUDNESS - The SENTINEL continuously measures program loudness according to the recent ITU recommendation BS.1770-1 (see below left). The resulting dB LeqLRB (LKFS) reading may be used to monitor the loudness for a surround program. The instrument also measures, logs and displays dialog loudness. The measured value may be compared to the dialnorm value or be used to externally set the dialnorm value for a program.

To insure compatibility with other loudness measurement methods the SENTINEL includes selectable A-weighting filters and adjustable averaging time. Its power as a loudness measurement tool is greatly expanded when the graphical analysis capabilities described below are applied.

CONTENT - It is often helpful to characterize the content of a surround program. At its most basic level the octave band spectrum can give useful information about program balance to complement the loudness measurements. The spectrum is also useful in assessing the importance of downmix compatibility issues. If a signal has little content at high frequencies cancellations there will not seriously impact the sound quality of the program. As visible in the figure above, there is an octave band resolution Spectrum display below the loudness readings and immediately above the Downmix Compatibility display.

Additionally, to assist in monitoring individual channels and their content there is a spectral distribution measurement for each channel. These are located immediately below each channels level bargraph. They change width to indicate the approximate bandwidth of each channel, extending left for low frequency energy and extending right for high frequency energy. A flat spectrum input will cause the horizontal bar to extend the full width of the bargraph. Dialog will create a medium width bar biased towards the left.

AUXILIARY INPUTS -

The SENTINEL includes 6 auxiliary DC inputs with a measurement range of 0 to 2.55V. It also monitors its own temperature, generally only slightly above that of the rack in which it is mounted. These voltages can be assigned user defined labels and, along with temperature readings, are saved in the logs and can be shown on the Display page. Alarms can occur when any of these fall outside user-set minimum and maximum values.

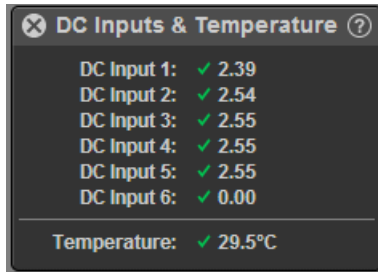

TIME STAMPS - The SENTINEL includes an LTC input which can connect to a facility-wide time code signal. It also includes a highly accurate real time clock/calendar which time stamps all measurements and errors. This allows precise identification of events in both program position and time, greatly assisting diagnostic efforts. Both of these are displayed in the status bar below the main display and stored in the log file.

METADATA - The digital input versions of the SENTINEL extract metadata from the applied signals. Sample rate, active word length and frame alignment are also measured for each of the inputs. The metadata and the measured data are displayed, checked for consistency across channels and checked for consistency between the measured values and the metadata values. As with all other data these are also logged.

The large number of channels (up to 8) in surround programs makes displaying the metadata in a clear manner very difficult. The solution, shown at right, is to display only one complete set of metadata. The set is divided into logical groups and for each group a set of flags identifies which channels are described by that metadata. If all channels have the same metadata, all flags will be illuminated and the displayed metadata won't change. This is illustrated by the Sample Time and Time Of Day displays in the figure below. If metadata differs across channels the displayed metadata will cycle through the different values and the corresponding channel flags will illuminate. The Source information in the figure above applies only to the two channels of input 4 which also has a different word length from the other channels. Even within input 4 the Destination data is different on A and B channels.

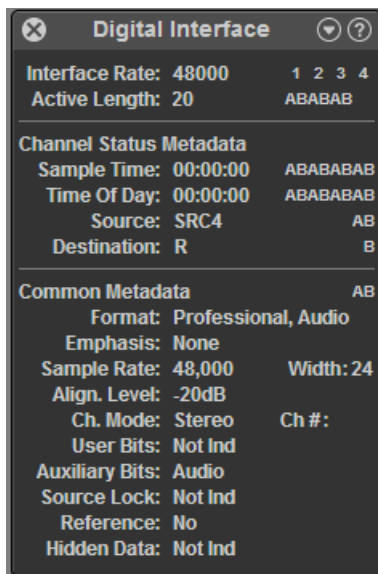

The metadata checks help find problems that could affect the reproduced audio. The cross-channel checks and

measurement-metadata checks help identify channels which don't belong in a surround group as can happen when routing switchers are misprogrammed. In the figure at lower left it is evident that the inputs contain a 6 (5.1) channel surround signal and an auxiliary stereo pair.

If the optional Dolby decoder is present, the Dolby format is identified and metadata as well as audio, are extracted, displayed and checked. Dialnorm is compared to the value measured on the program material itself and discrepancies are identified. The Dolby metadata display is shown above, displaying a Dolby Digital 5.1 signal from a DVD.

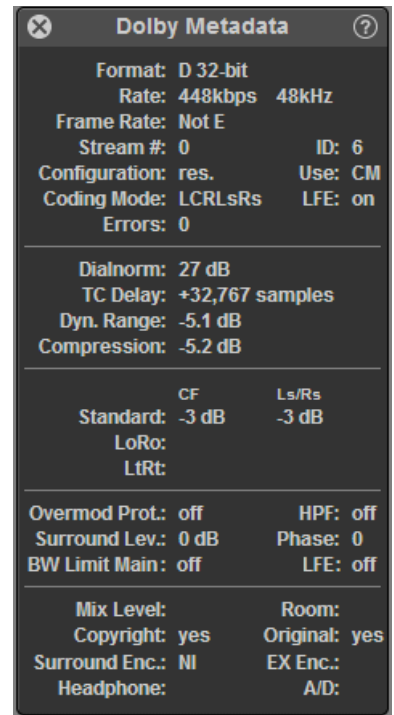

ERRORS - Almost all of the measurements may be compared to specified limits and produce an error if these are exceeded. All error checks allow control over relevant parameters and thresholds including the ability to specify how long a problem must exist before it is determined to be in error. This allows exclusion of transient problems which may not exist long enough to be of practical importance or which have some unavoidable minimum duration. The user is freed from sifting through numerous unimportant warnings to guard against the occasional serious problem.

Errors relevant to individual input channels are displayed in a text overlay for each channel. Errors in channel balance appear as overlays in the balance display while stereo and mono compatibility errors are shown in the downmix compatibility display.

Errors are also summarized in one display panel shown at right. Unlike the bargraph overlays which only show the highest priority error existing at any time, the summary panel shows all errors. It also includes a user selectable hold time so prior errors remain displayed in yellow for up to 30 seconds.

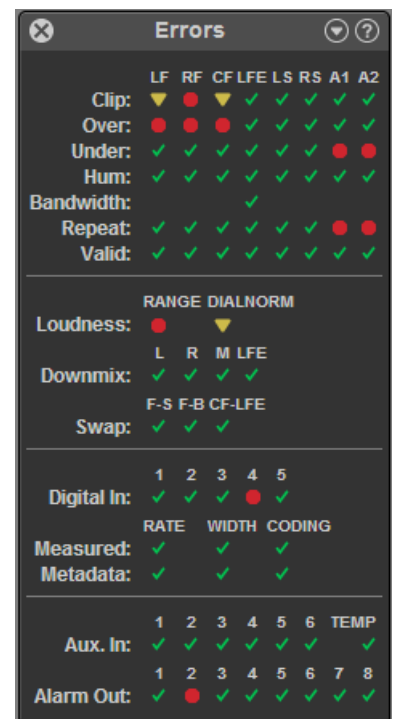

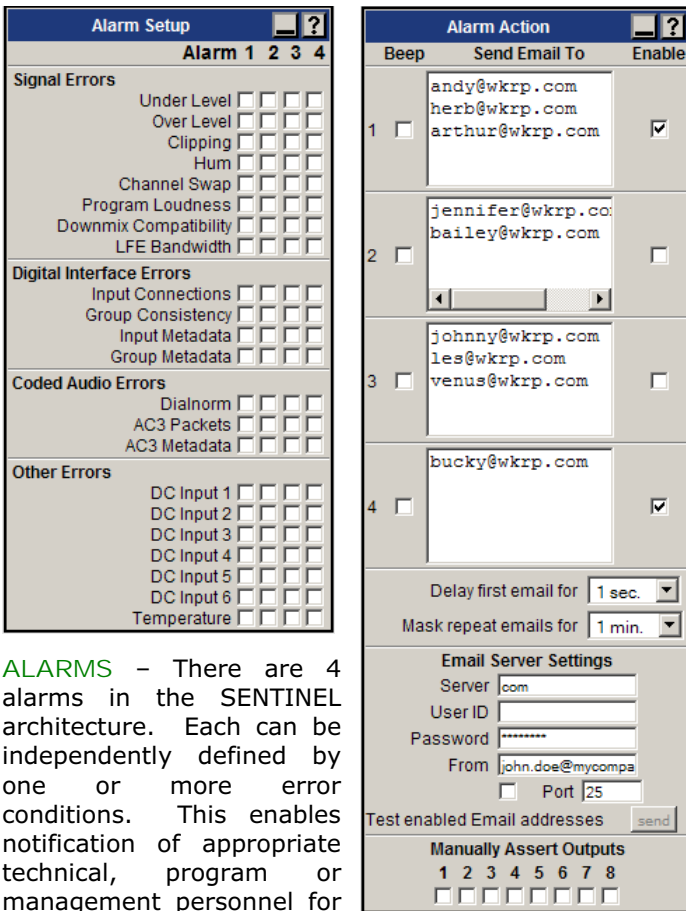

ALARMS – There are 4 alarms in the SENTINEL architecture. Each can be independently defined by one or more error conditions. This enables notification of appropriate technical, program or management personnel for differing types of problems.

The Alarm Setup panel above is used to define the mapping from errors to alarms, allowing any desired error type to generate any combination of the 4 alarms.

The actions taken when alarms occur are specified in the Alarm Action panel. An Alarm can cause any combination of contact closure, audible or visual indication and generated emails. Up to four email addresses may be entered into the SENTINEL. For example, technical personnel may be notified if signal loss occurs and program personnel notified when compatibility or loudness issues occur.

One root problem may cause several errors. Consider the case of a failed AES/EBU link carrying the LF and RF channels of a surround program. This will result in a loss of lock error for the digital link. It will also cause under-level (dead channel) errors for both channels. It will likely also cause a front/rear swap error since the rear channels will still have signal. To prevent the

SENTINEL from sending three separate emails from this one failure, email generation may be delayed for a user selectable period allowing all three errors to be contained in one email.

Measurements are continuously made meaning an error is likely to be found in a series of successive measurements. To prevent a continuous stream of emails containing no new information, repeat emails may be masked for a user selectable period. When an email is sent reporting one or more types of errors another will not be sent until the specified time has elapsed. An error of a type which has not been reported during the masking interval will be sent after the normal email delay.

LOGGING - Levels, loudness, compatibility, metadata and all other measurements and errors are logged in an internal memory. Every 1.4 seconds, everything the SENTINEL measures is compressed and saved. The maximum and minimum bargraph values, the maximum true peak reading, any asserted error flags during the 1.4 second interval are saved for each channel and downmixed channel. All multichannel measurements including loudness, downmix compatibility across frequency, etc. are likewise saved.

Unlike other products which provide a logging feature, the Sentinel stores data whether or not errors are generated. If listener complaints are received when no errors were generated the logs may be consulted to determine how to revise error thresholds so future problems will generate errors in advance of listener complaints. Similarly, if errors occur and no listener complaints are received, logs may be consulted to determine how far thresholds may be relaxed without missing problems. With all channels in use and all error checking enabled, the memory can handle more than 24 hours of data. This data may be downloaded via the browser interface. Alternately, a script may be executed on a networked PC to download the log data at periodic intervals. These logs may then be stored indefinitely.

If, for example, loudness complaints are received on Monday for a program broadcast the previous Friday evening the log files provide an easy means to prove compliance with relevant requirements or to investigate the causes of a failure. The data is measured in accordance with industry standards and so becomes an authoritative accounting of what occurred.

TIMELINE DISPLAY - The browser display includes the ability to graph user selected measurements as a

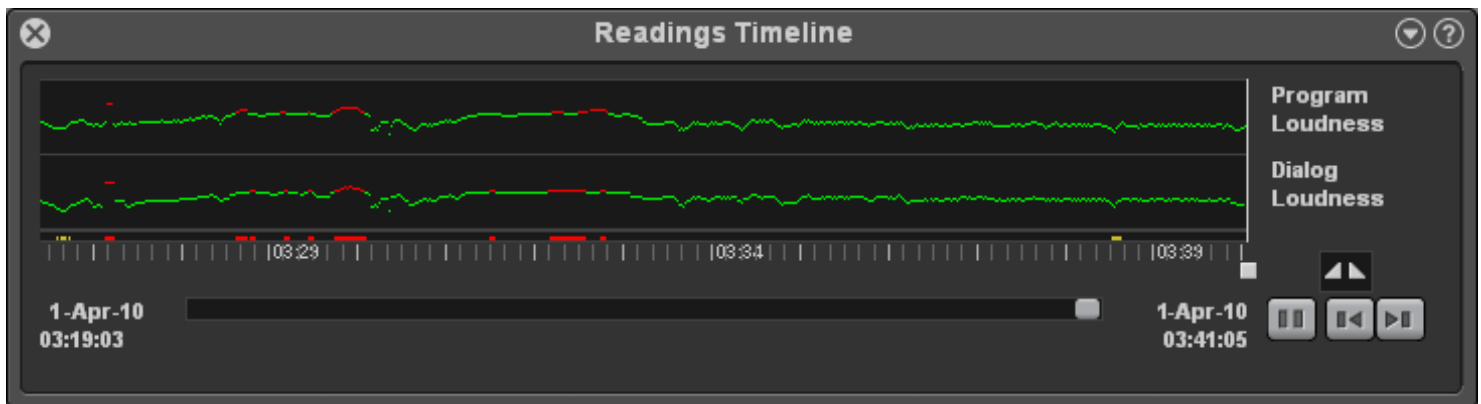

function of time. The "strip chart" displays facilitate an intuitive understanding of the audio signal. Graphs of loudness or surround compatibility vs. time provide a rapid understanding of the signal history. This allows comparing the audio between program and commercials or between different segments of a program. Trends become apparent, the disparity between content and commercials becomes obvious, conclusions can readily be drawn. In addition to the selected measurements (up to 3) an error summary is presented along the bottom edge of the graph. If an error occurs a yellow dot is placed at that location. If the error resulted in an alarm condition the dot becomes red.

The display directly shows whatever has been received by the browser since it was started, but its power extends far beyond that. The graphics system is integrated with the logging system enabling it to display logged data as easily as it displays recently received data. Whether the log was saved an hour ago or a month ago, whether the data is in one log file or multiple files, the system seamlessly transitions between them displaying the data in timeline form.

The timeline display includes a current position cursor and multiple segment selection cursors. In normal operation the current position cursor rests at the right hand edge of the timeline display as the bargraphs, balance display, compatibility display, etc. show real time data. When the current position cursor is dragged away from the edge and positioned anywhere along the graph the displays freeze and instead show the data corresponding to the cursor location. Drag the cursor to a yellow or red error or alarm flag along the bottom of the graph and the Error Summary panel will show all the error and alarm conditions in effect at that time. Every measurement on each display panel will then show the same value it did at the specified time. All measurements, error flags, metadata, auxiliary inputs ... *everything* exactly matches its state at the selected time. Whether the cursor is positioned one minute or one month ago, the relevant data is retrieved from the logs and displayed. There is no need to sift through text based logs to examine what happened.

The segment selection cursors allow identification of a specific time period for further analysis, simply set one to the beginning and one to the end. The selected portion may be played back at normal speed or at multiples of normal speed.

As the data is played all the displays will reproduce the values they had when the original measurements were

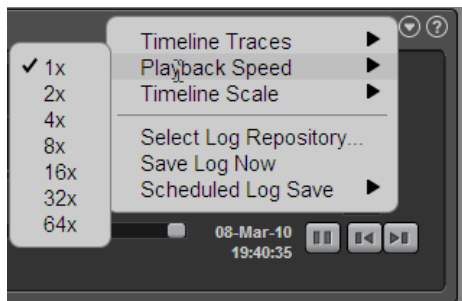

taken: bargraphs will move, error flags will flash, etc. only limited by the 1.4 sec. resolution of the log file data. Multiple segments may be identified and played back in succession or

compared using the histogram display.

HISTOGRAM DISPLAY – The measurements graphed during the period identified by the segment selection cursors may be displayed in a histogram. If multiple segments are selected multiple traces will appear in the histogram. This is extremely powerful when examining loudness across segments of a program, comparing loudness of commercials or examining the loudness of a commercial compared to the program which carried it. Overly compressed material is readily identified as are program segments which deviate excessively from the remainder of the program.

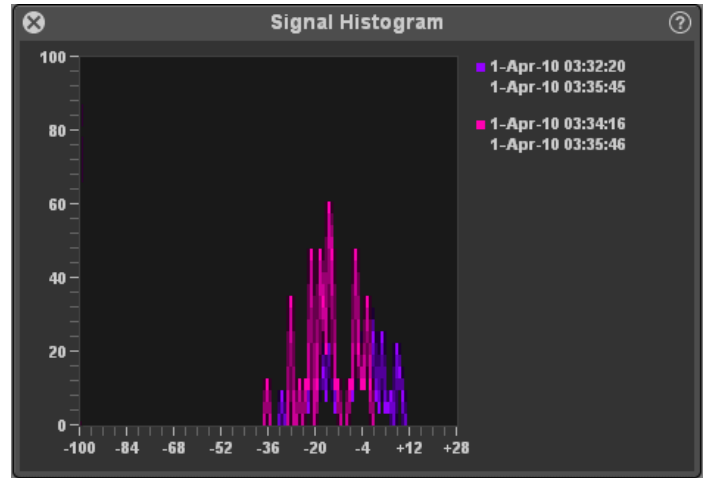

HELP SYSTEM – The displays and settings panels all are hyperlinked to an online help system. Each panel will launch a browser window displaying the section from the users manual relevant to the panel being queried. The help system may be navigated by hyperlinks contained within or by continuing to use the help icons located on each panel.

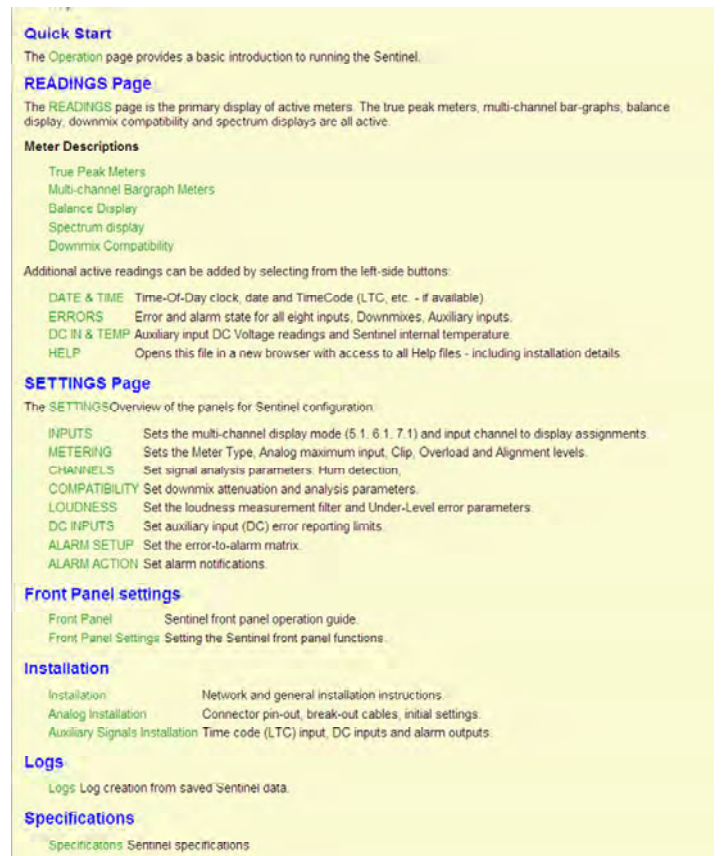

Available Input Modules

Sentinel A Analog Input

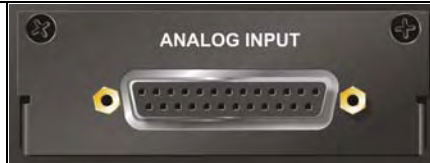

8 Analog input channels
Balanced or unbalanced format
Maximum input +22dBu or +28dBu
1 MΩ Impedance for high CMRR with unbalanced source impedance
TASCAM standard connector pinout

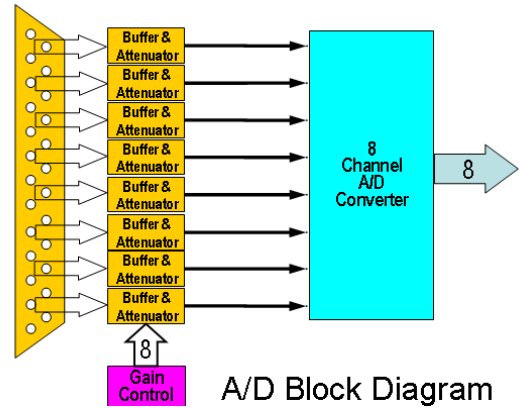

Sentinel D AES-3 Input

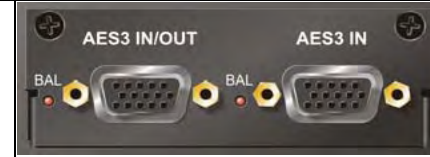

8 Measurement channels
4 AES-3 PCM inputs
1 AES-3 Coded audio input, selected from 4 input sources, drives AES-3 output and optional decoder
Balanced 120Ω or unbalanced 75Ω
Optional Dolby CAT552 decoder, decodes both Dolby Digital & Dolby E, driven from selected one of 4 AES-3 coded audio inputs.

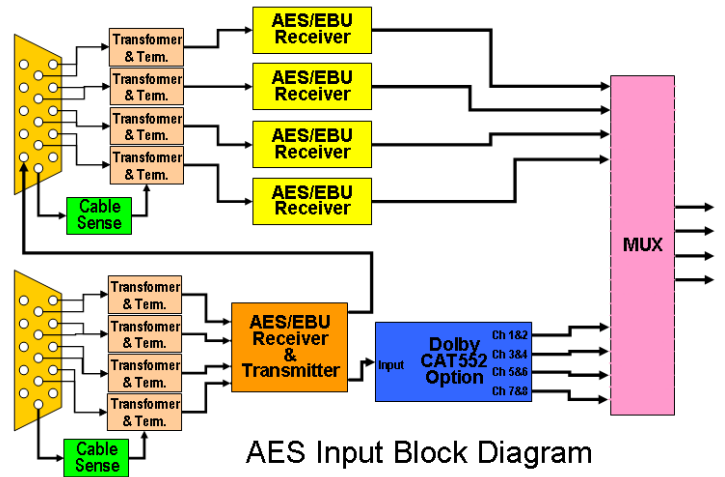

Sentinel S SDI Input

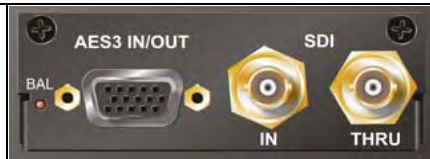

8 Measurement channels
1 HD/SD SDI input with buffered loop-through output
Accepts 3G SDI
De-embeds 2 audio groups to obtain 8 measurement channels or one coded audio stream.
4 AES-3 PCM inputs
Optional Dolby CAT552 decoder decodes both Dolby Digital & Dolby E. May be driven from any SDI channel

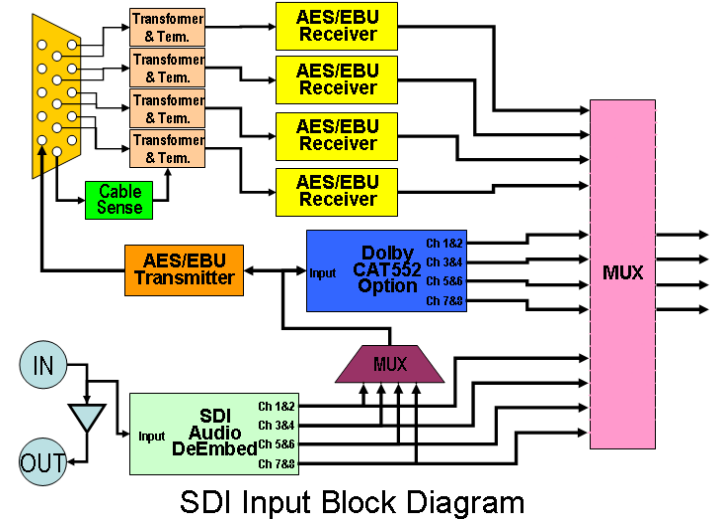

Included Accessories

DB25-SCR

DB25 to screw terminal adapter

Simplifies connections to the auxiliary I/O connector
Includes removable pull-up resistor networks

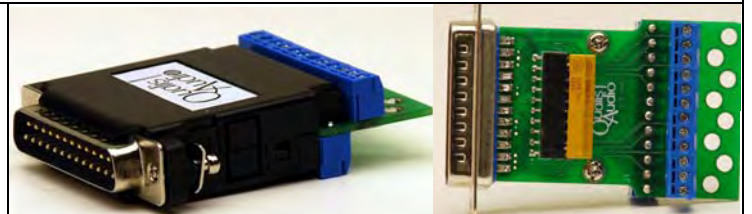

Technical Specifications

Analog Inputs

Connection	8 ch. on 25 pin female D-sub, compatible with TASCAM 8-female cables
Format	Balanced or Unbalanced
Input Impedance	1 M Ω , each side to ground
Maximum Input	+28 dBu or +22dBu, selectable
CMRR	>50 dB to 2 kHz, 10 Ω source imbalance
Response	+/- 0.1 dB, 20 Hz to 20 kHz
S/N	>105 dB, 20 Hz to 20 kHz
Crosstalk	>80 dB, 20 Hz to 20 kHz

Digital I/O

Input Format	AES-3 120 Ω Balanced or 75 Ω Unbalanced
Output Format	AES-3 75 Ω Unbalanced
Word Width	16 to 24 bit
Connector A	4 AES-3 inputs (8 ch.), 1 AES-3 output on one 15 pin high density female D-sub
Sample Rate	32 kHz to 192 kHz, each AES-3 stream asynchronous to all others
Connector B	1 AES-3 input selected from 4 AES-3 inputs on one 15 pin high density female D-sub
Sample Rate	32 kHz to 48 kHz
Cables	Unbalanced inputs use VGA to BNC cable, Balanced inputs use a custom DB15HD to 4 XLR / 1 BNC cable, not included

Auxiliary I/O

Connection	1 on 25 pin female D-sub
LTC Input	Balanced, AC coupled , 22 k Ω , 5Vpp max
Auxiliary Inputs	6, 2.55VDC, Unbalanced, ground referenced
Alarm Outputs	4, Open collector, 24V/100mA max
GP Outputs	4, Open collector, 24V/100mA max

Miscellaneous

Network	10 Base-T Ethernet, RJ45 with status LEDs
Chassis	1.75" H (1U) x 17" W x 7" D (8.9 cm x 54.2 cm x 17.8 cm)
Power	24V at 0.5 A max from external adaptor
Power adaptor	100V/120V/240V, 50/60 Hz, 15W

Ordering Information

Sentinel-A Analog inputs

Sentinel-D AES-3 digital inputs

Sentinel-S SD/HD SDI and AES-3 digital inputs

Combinations of two inputs are available on request. Contact your sales representative or Qualis Audio for more information

Opt-552 Dolby Digital & E decode for Sentinel-D/Sentinel-S

Intellectual Property Notice

The Qualis Audio SENTINEL and the embedded software are the subject of numerous patents pending.

About Qualis Audio

Qualis Audio was formed by Dr. Richard Cabot, formerly CTO of Audio Precision.



PO Box 731
Lake Oswego, OR 97034
voice 503-635-9376
fax 503-635-3851
www.qualisaudio.com

Surround Analysis

Formats	5.1, 5.1 + 2, 6.1, 6.1+1, 7.1
Metering Standards	VU, Nordic PPM, BBC PPM, EBU PPM, DIN PPM, proprietary 128 dB meters
Loudness	Program Loudness and Dialog Loudness according to ITU-R BS.1770-1
Downmix	Computes energy lost during downmixing to both stereo and mono formats
Compatibility	Analysis in 1/24 th octave resolution
Channel Balance	Displays L, R, M results in octave bands
LFE Analysis	Measures and displays channel loudness relative to the loudest channel
Channel Interchange	Measures LFE BW, LFE downmix loss
Spectral Analysis	Detects front/surround reversal by level comparison
Channel Analysis	Detects CF/LFE interchange by bandwidth comparison
Channel Loss	Measures program energy in octave bands

Channel Analysis

Channel Loss	Compares individual channel loudness to user specified threshold and duration
Excessive Level	Compares individual channel levels to user specified threshold and duration
Hum Detection	Detects mains freq., 2 nd and/or 3 rd harmonic

Digital Analysis

Interface	Measures sample rate
Data	Detects loss of lock, parity errors
Metadata	Detects cross-interface inconsistency
Other Analysis	Detects digital zero and digital clipping
DC Inputs	Measures bit activity, active word length
Temperature	Detects cross channel inconsistency
Included Accessories	Analyzes status bit metadata
Optional Accessories	Detects metadata inconsistency

Other Analysis

DC Inputs	Compare to independent min & max values
Temperature	Compare to min & max temperature

Included Accessories

110/220V 50/60 Hz power supply, DB25 to screw terminal adapter rack screws, printed manual.

Optional Accessories

HD15-FXLR Balanced AES-3 cable, terminates in 4 XLR, 1 BNC

DB25-SCR DB25 to screw terminal adapter (one included)

SENTINEL, Qualis Audio and the Qualis Audio logo are trademarks of Qualis Audio.

The Sentinel is the result of his efforts developing algorithms for analyzing and processing surround program material.